

Solar Dryer



Solar dryer used in India; the base-plate is corrugated roof with aluminum foil on the backside

Content

Background.....	1
Benefits of solar drying.....	2
Technical details.....	3
Size of the fan.....	3
Size of the Solar Panel	3
More Details	3
Costs and maintenance.....	6
Project Basics	7
Construction	7
See extra file „Summary of the book "Drying food for Profit" for more Info.....	19
Features in short	19
Some marketing-arguments	20
Getting started.....	20
Links and Resources:.....	21
Contact.....	21

Background

- Up to 50% of the fruits and vegetable and 25% of the harvested food grain rotten in the tropical countries
- During the harvest the high quantity of food can not be sold for a good price!
- Harvest turns into storable and tradable goods for a long term.
- Stored goods are a regular source of income and diminish the dependence on seasonal Harvest.
- Drying in the direct sun has the risk of damaging the complete harvest by rainfall
- Animals decrease the quality of the product by open drying.
- By drying the farmer can have more income and for a longer time
- Such a dryer can be built in one day for less than 100\$! And you really can make money with it by selling the good quality and delicious Product!

Aspect for coffee drying

Conventional coffee dryers consume large amounts of wood and electricity to dry the beans after the washing process. An estimated 16,000 acres of forest are destroyed to supply the firewood used to dry the coffee production each harvest.

The solar drying process gives small growers the capacity to dry their coffee beans themselves, which adds value to the product since dry beans are stable and much more valuable than beans that must be sold wet.

Benefits of solar drying

- Dried foods are tasty, nutritious, the nutritional value and flavor of food is only minimally affected by drying
- Dried foods are high in fiber and carbohydrates and low in fat, making them healthy food choices
- Vitamin A is retained during drying
- Storage space is minimal, easy-to-store
- Transportation costs are reduced; dried Products weigh only about 1/6 of the fresh food product
- The energy input is less than what is needed to freeze or can
- easy-to-prepare; solar food drying is a very simple skill
- longer storage of dried products (because of more complete drying)
- Can open new markets and income and is a good start-up technology. It improves the bargaining position of farmers. Sometimes farmers sell at very low prices during the harvest season
- You can have up to 50% more productivity in agriculture
- For diabetics dried fruit prepared without adding sugar is a healthy choice instead of desserts.
- Dried fruit can be used in stews, soups and casseroles or enjoyed as snacks. It can also be added to cereals for breakfast or used in making ice cream and baked products
- It is a absolute safe technology. No high voltage is used, no risk of high Temperature not any harm could be generated by the dryer.
- The food is safe, although it could be contaminated before drying. Because of the pasteurization-effect due to “high” temperature in the dryer.

Compared with open-air drying

- Protection of the drying products from insects but also from birds, dogs, especially for drying meat and fish.
- the product is hygienic because microorganisms, insects and flies are killed
- protection of rain
- Protection of pollution by dust etc.
- Protection of the wind which can blow away the food.
- reduction of drying time (reduces changes through spoilage)
- no need to turn the product because air passes both sides of the product
- no loss of colors of the product (tomato, paprika powder etc)
- Drying is faster because inside the dryer it is warmer than outside
- Less risk of spoilage because of the speed of drying. (if the drying process is slow the fruit start to ferment and the product is spoiled).
- It is labour saving. The product can be left in the dryer overnight or during rain.
- The quality of the product is better in terms of nutrients, hygiene and color

but:

- more expensive than with direct sun drying (Solar dryer costs about 70 \$)
- if you have huge quantities to dry you need big dryers.

Technical details

Size of the fan

- The use of forced convection by a fan can reduce drying time by three times and decrease the required collector area by 50%.

- The ventilator can be a car-ventilator or from a Computer driven by an appropriate Solar panel. Size of ventilator around 200mA / 61 m³/h;

There is a electronic Temperature-Regulation available from www.alternative-technology.de/Solar_Dryer/solar_dryer.html

If you do not have a Solar-Panel and a regulation-electronic use a Power-Supply 8-12V with variable Output-Voltage to adjust the Speed of the Fan manually. In the first night it is better to leave the fan running (high humidity), later may be it is better to be off in the night.

For the order of the fan: 1 cfm = 1,699 m³/h;; 1 cfm = 0,02832 m³/min; For the above described unit 61 m³ /h is ok.

- If one fan can not manage the air-flow, take two or three. Check that the regulation-Unit can manage this!

- Take care of the wind-direction of the fan! Should **go from outside to inside**.

- if no Ventilator is used turn the dryer in direction of the wind. If there is no wind, then point the dryer south in the northern hemisphere (north in the southern hemisphere).

Per m² black (Collector-) Area a Volume-flow of 40 to 50 m³/h Air is necessary. That means the fan for this construction should have about 61 m³ /h. A 12 V fan for a computer can do the job. Take a regulated Power-Supply 6-12V and you can adjust manually the fan.

Order-number for the fan at Conrad electronic Germany: 53 73 30 59 or 53 71 60 59

Or Reichelt electronic: (www.reichelt.de) FAN-ML 8020-12

Question: Can I use a fan from a Car?

Answer: It may be too big to fit to the front and they are sometimes very strong, may be produce too much air-flow.

Size of the Solar Panel

Current Fan + 20% * Voltage (12V?) = Power of the Solar Panel; around 6-10 Watt for a Standard-Size

The solar module should be sized so that, even with an overcast sky, there should be a little flow of air in the dryer.

More Details

- Professional Dryers are 20 m long but have the same Design like this Tunnel-Dryer. So this version is may be a good starting-Unit to make experience and for smaller-scale business. Anyway sizes can be modified but keep the height! This is a calculated figure! For sure you can also work with several dryers.
- **The height of the dryer should be constant, although you make it bigger.**

- For Basic understanding: A solar tunnel dryer with taller peak height has a larger air volume to absorb water vapor but it takes longer to heat the larger volume of air, resulting in a lower air temperature. The taller peak height also has less wind resistance allowing faster airflow.
And reverse: A shallow peak height has a smaller volume to absorb water vapor but the smaller volume heats up faster. The shallow peak height has more wind resistance. Therefore these parameters are optimized in the constructions below.
- Higher operating temperature increases the water holding capacity of the air thereby increases the evaporation rate.
- For the **grill** to put the food on use **aluminum or stainless steel** (but very expensive!) but should be food-compatible. Aluminum-grid is a good choice **stainless steel** might be too expensive. Galvanized hardware or copper screens are not recommended for to put the food on it as potentially toxic salts can migrate into the food.
- The black part of the dryer should be a dull / matt black color (best if food proof) or also a UV-resistant PE-Plastic foil or a black fleece.
- Below the crops there can be a mat of Palm sticks.
- Cool night air can have condensate as consequence. So cover the Unit with a blanket or bring it inside if there is a risk for that. But that happens only if the temperature decreases a lot. Normally you can let it outside.
- Protect the area of animals that can harm the Dryer. Mosquitoes can not come in!
- For to cover the dryer: Take the Plastic sheet available for a glass-house or any other UV-resistant material. If not available, you can also use several smaller sheets by overlapping them to a bit sheet. The part with the black side can be always fixed. And only the product side to be open / close. Do not miss to have a good overlapping of both sides that no rain can come in.
- If that's also not enough or if no sun is available: expose the food to a flow of dry air heated by electricity (there are low-power 12V / 120W heater available for cars) or propane gas.
- Ants and other crawling insects may be blocked from the trays of food by placing the feet of a rack in containers of water (see right).
- All dried foods will be pasteurized after drying except for the greens and herbs
- Solar driers are usually designed to dry a batch in 1 to 3 days. Bigger slices may need more. Fast drying minimizes the chances of food spoilage.
- Once the drying process has started it should not be interrupted and do not allow to freeze
- Direct sunlight is often not recommended, especially for herbs etc. Direct sunlight destroys some of the more fragile vitamins and enzymes and the food loses color. For

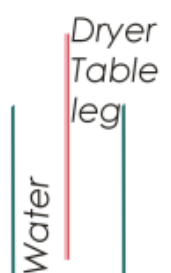

light-sensitive plants cover the production-area with a textile or blanket, but not the area with the black paint.

- You can install several fan and test with it (1 or 2 and more) to get best performance. You can switch some fans by a switch. In that way you can better adjust the air-flow.
- Anyway you can try to design it in the way that you can put several layer of food in the dryer to increase load. But I would try testing with one layer and get a feeling for the best time and speed of fan, 1 or 2 etc. And then start making experience with 2, 3 layers. But it is also a construction-challenge.
- For the bows to hold the plastic it is enough if the first and last and middle is quite stable. The others can be so and so.
- You can make the grid for the product about 10 cm overlapping over the black area, to get better performance, due to the product is not going to the end of the grid.
- You can paint also the inside walls black, around the black area, to get more absorbing surface. I did not try but may be interesting will be to paint all black inside. You will get higher temperature. You need more fans, but have a faster drying.
- If you do not have a Solar Paneel, there are small unregulated transformers from China where you can switch the voltage by 7,5V, 9V, 12V etc. In fact 12V is not really 12V, it depends from the load connected and is mostly much higher. But the fans can normally manage that and you can adjust the air-flow by the voltage. In the beginning and with full sunshine a higher voltage, at dawn and low sunshine switch to low voltage or off.
- You can make a removable grid, to be taken out to the front-side. But also the front-side with the mosquito-grid must be removable. That makes it easier to charge, discharge and clean the dryer. (see pictures below). You can bring it in the house and the whole family can fill it. And you can also turn the grid for a more homogenous drying.
- If you have 2 fans, one is spare. If one fails, the other one will go faster with the Solar-Panel and you have time to replace.
- Take care that all is covered with plastic and no water can go in, that you can leave it outside in the rainy season. But may be in the rainy season, it makes sense to protect it more against damages on the wood.
- For good rain-protection especially in the tropical, the plastic should be well overlapping the end (may be 20 cm) and also the upper timber should be 15 cm longer, that the plastic is not covering the Inlet / Outlet.
- Covering the fan by a household-sieve make sense, because it is a good rain-protection.
- The plastic should go on both sides well above the end (may be 30 cm), but not cover air inlet and outlet to avoid the heavy rain come in the dryer. So you need to extend the top wood which holds the plastic outside the end.

You can make other sizes of dryer

but the ratio of black area to drying surface should be 1:1.

- The height should be maintained approximately, even if the drier is longer or wider
- Keep Fan-Size per square meter black area 40-50 m³/h air (about one fan)

Should I switch off the fan in the night, if I do not have a Solar-Panel?

In the first night it is better to leave the fan running (high humidity). Later may be it is better to be off in the night if there is risk of cooling down the product too much.

Should I paint all sides inside black of the dryer?

You can do that, increases the performance of the dryer a bit if the grid is not full with product.

Which products should be covered to protect from sunlight?

The Plants with Chlorophyll (leaves), that could bleach

Drying in 2 Layers?

Is possible but lower layer will dry more slow, due to not being exposed to sunlight. So may be changing the layers from time to time. And all drying will take longer. Better is one layer completely full.

More Information, for professionals

- If you have a moisture-measuring device: Adjust the dryer (peak height of the plastic-cover, airflow rate and amount of products placed in the dryer) to achieve < 50% relative humidity in the exhaust air.
- Parameters for the speed of evaporation is the solar radiation, wind speed, relative humidity and air temperature. Time for drying also varies with the thickness of the fruit.
- A higher airflow rate is required to remove moisture (usually in the first 30 minutes). The airflow rate can be reduced later in the drying process.
- If the sun is not sufficient then you can increase the heat by putting a black pipe or copper pipe (may be 1m long and diameter of the fan) before the fan for to preheat the air.
- To fully exploit the performance of the drying system, the dryer must operate at the maximum drying temperature of each product, where just no reduction in quality occurs. Laboratory experiments have shown that almost all fruits can be dried at a temperature of 60 °C without significantly affecting the product quality. Higher temperatures lead to browning reactions and to Case hardening.

Costs and maintenance

- around \$50-100\$ you can make a dryer and enjoy the fruits (and veggies) and even sell them.
- There are cheap sealing-devices for plastic available.
- Solar drying equipment generally requires little maintenance.

- Compared to other solar dryers, the capacity of the tunnel dryer is much higher.
- A pay-back period of approximately two years for this solar tunnel dryer. The pay-back Period can be reduced considerably if the dryer is used for multi-products

Project Basics

The project should be initiated by the aid receivers
 the village should be participated financially
 the project should involve a local experienced partner
 the technique should be as simple and adapted as possible
 the system should use only local materials

Construction

The outlet-Mosquito-Net can be on a frame for better cleaning

Materials

Materials

Curve for Plastic
 Front-Holder (optional)
 Top-Bar
 Holder f.Curve(optional)
 Ground-Plate
 Side-Bar
 Front with Fan-hole
 for to hold Plastic
 Side-Holder (optional)
 Front/Back-Bar (optional)
 Frame for metal screen
 Metal screen
 Bock/Table (may be put on table)
 Ventilator 60m3/h
 house-hold-sieve (or take part of the grid)
 side-bars
 Plastic to wood
 Plastic to wood
 screws to fix ventilator
 Mosquito net for Outlet (or take part of the grid)

Material	Input =	fix=	Calculation=		
	Dimension (mm)	mm	mm	Number	Price in \$
Bar of wood	1115	27	5	4	3
Bar of wood	1000	30	5	1	5
Bar of wood	2200	30	5	1	2
wood (5 mm)	60	23	5	8	
plywood	2200	1000	8	1	15
plywood	2200	100	8	2	5
plywood	1000	225	8	1	4
Metal or Alu	2400	20	20	2	3
Bar of wood	2200	30	50	2	
Bar of wood	975	30	50	2	
	1100	40	20	4	3
	1100	1000			4
Bock/Table				2	
Ventilator	100	100	2	1-2	4
to cover Ventilador					0
big screws	Ø4.5 X 40			46±4	0.1
small screws				20	0.1
screws (+ disc spa:disco) + rubber	Ø3 X 10 / Ø12 X 3			16+16	0.1
screws to fix ventilator				6	0.1
Mosquito net for Outlet (or take part of the grid)				1 m2	0

UV- resistant, transparent Foil	2400	1400		1	6
Plastic-Foil dull black colour				1/2 l	4
Solar module with cable for the Fan or				0	0
Transformer 220V / 12V				1	5
Cable for Solar Module				3-5m	2
Grating, grid, trellis(deu:Gitter)	1100				10
Frame for metal screen	1100	5	5	2	1
Frame for metal screen	1000	5	3	2	1

For recalculation use the Excel-Sheet Part_List.xls (download from www.alternative-technologie.de)

Tools which help a lot to make it

- ✓ Hammer
- ✓ Screw-Driver
- ✓ Battery driven Screw-Driver
- ✓ Meter
- ✓ Saw

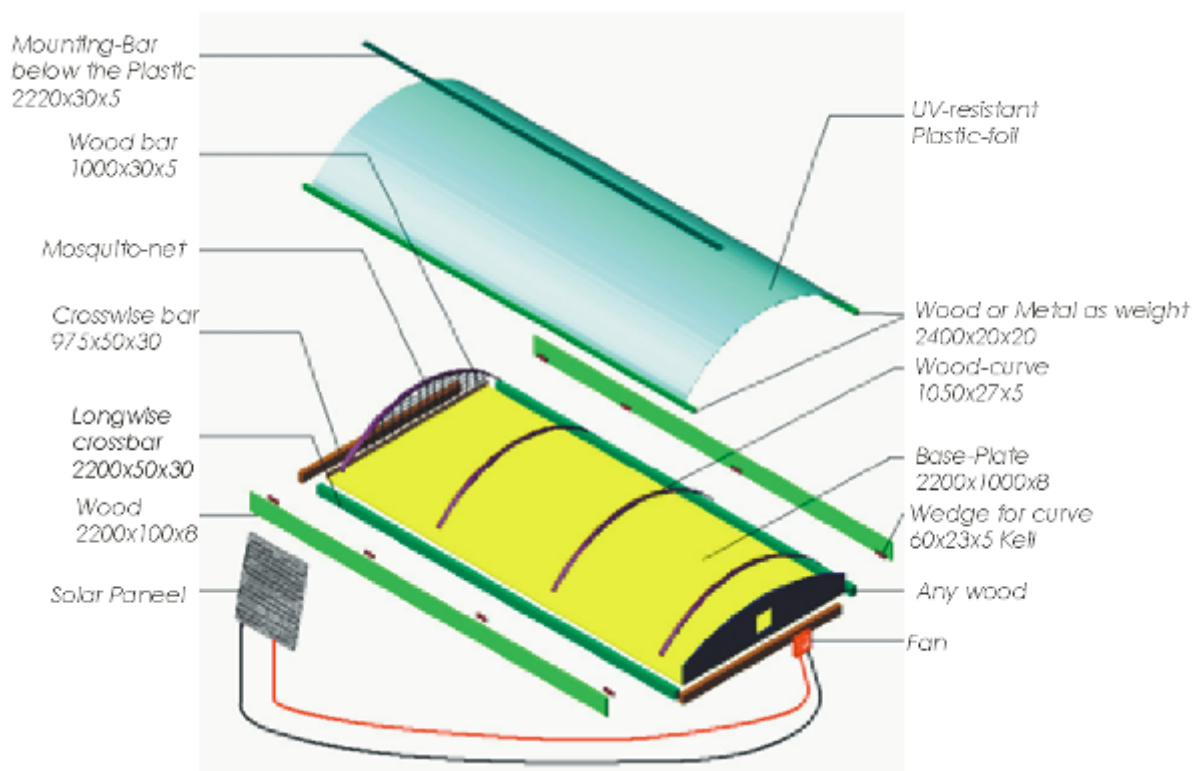

Parts for the Solar Dryer Type 2

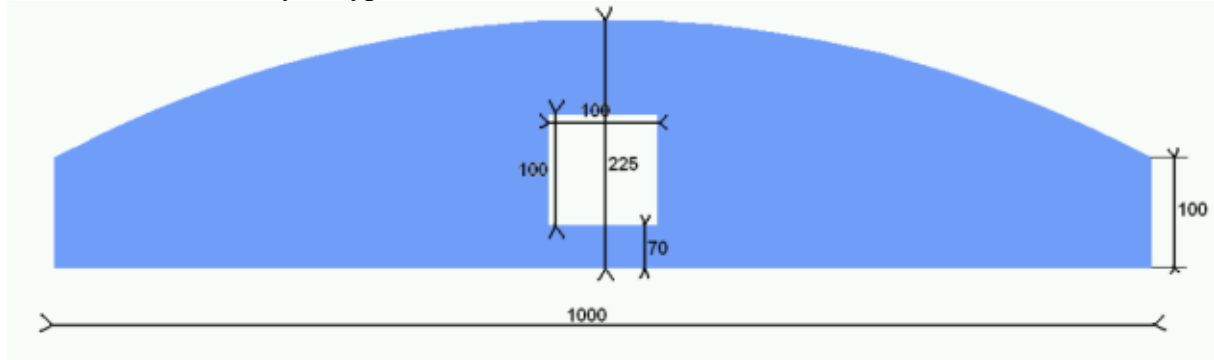

Sizing; Hole for Fan various according to your fan-size.



The side of the fan can be covered like this from outside, that the children do not touch the fan and no mosquito can go in and it is a good rain-protection as well; If the power of the fan is less than 200 mA use two fans. Mount the fan from inside and take care of the wind-direction! Should go from outside to inside.

The side opposite of the fan is open but covered with a net. May be on a frame

On the right side you see the grid by aluminum-wire. Can be stainless-steel as well.

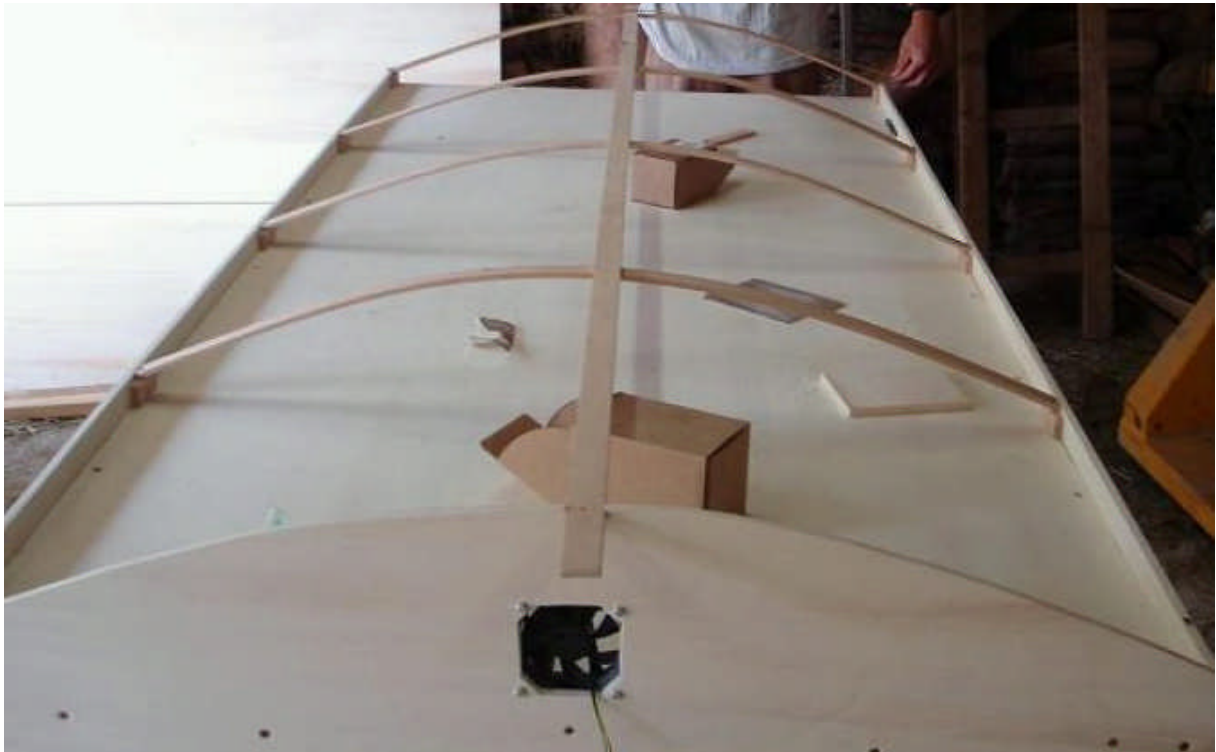

Type of holders for Type 2. You can put the round holders for the Plastic for at least one hour in water to get them bend more easy



you can also paint all area black of the full dryer!

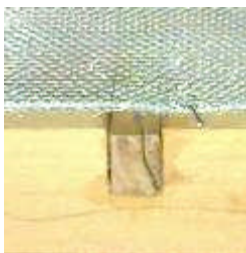

how to make a frame with low air-resistance



here the corner of the grid. But there a different ways to construct it.



One half of the Dryer is black (use food-compatible color if applicable or do not put food in this area). On the other half of the Dryer is the food.



Fig 8 : Winkelprofil auf der Unterseite

Hold the Plastic by a metal or aluminum bar or even stones. (Wood can rotten); Fix with screws, clips or a adhesive Tape.

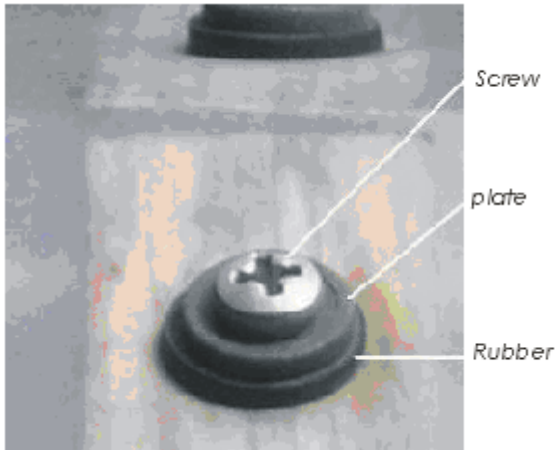

How to connect the Plastic-Sheet; Or put a second (short) wood above and screw it



Here the removable Side, to get the tray out. More interesting is with 2 hinge to flap it down.



Here you see the construction of the removable frame. Keep air-flow free from one end to the other of timber-blocks. Very useful having a removable tray, but keep in mind to have space enough to go through the door! May be passing it through a window..



Here you see the grid on Iron-Bars
Also a good idea to put metal bar under the fruits etc. Air can come from both sides! Or make 4 wood-bars (two at the side, two in between) to put a metal screen (see picture) on it. You can let the iron go on one side to the top curved holder that the fruit can not fall down. Bit this holders should be longwise with the air-flow. If you make a removable Grid, take care that the frame does not block the air-flow.



the dryer on it.

to put





Our dryer we made in Ecuador



Mixed products to test

Other Solutions for Dryers

anyway we made best experience with the dryer above

a) Part-List for the Solar-Dryer with a Solar-Panel Type 1

	Dimension (mm)	Number of
plywood (spa: contrachapeada (20 mm))	2070 X 1000 X 20	1
plywood (spa: contrachapeada (20 mm))	2050 X 30 X 20	2
plywood (spa: contrachapeada (20 mm))	1000 X 151 X 20	1
slat of wood (spa: listón de madeira); (10 mm)	495 X 25 X 10	6
rod de Aluminium (spa: vara de aluminio)	Ø 8 ,Länge : 2100	1
rod de Aluminium (spa: vara de aluminio)		
wire of high-grade steel (spa alambre	1416 X 20 X 3	3

Ventilator (spa Ventilador)	100 X 100 X 2	
screws (spa: atornillar)	Ø4.5 X 40	22
small screws (spa: atornillar pequeno)		12
screws (+ disc spa: disco) + rubber	Ø3 X 10 / (...) / Ø12 X 3	8+8
screws to fix ventilator		4
Mosquito net		
UV- resistant, transparent tarpaulin / Foil	2200 X 1400	1
Solar module with cable for the Fan		1
Table	See Photo	1

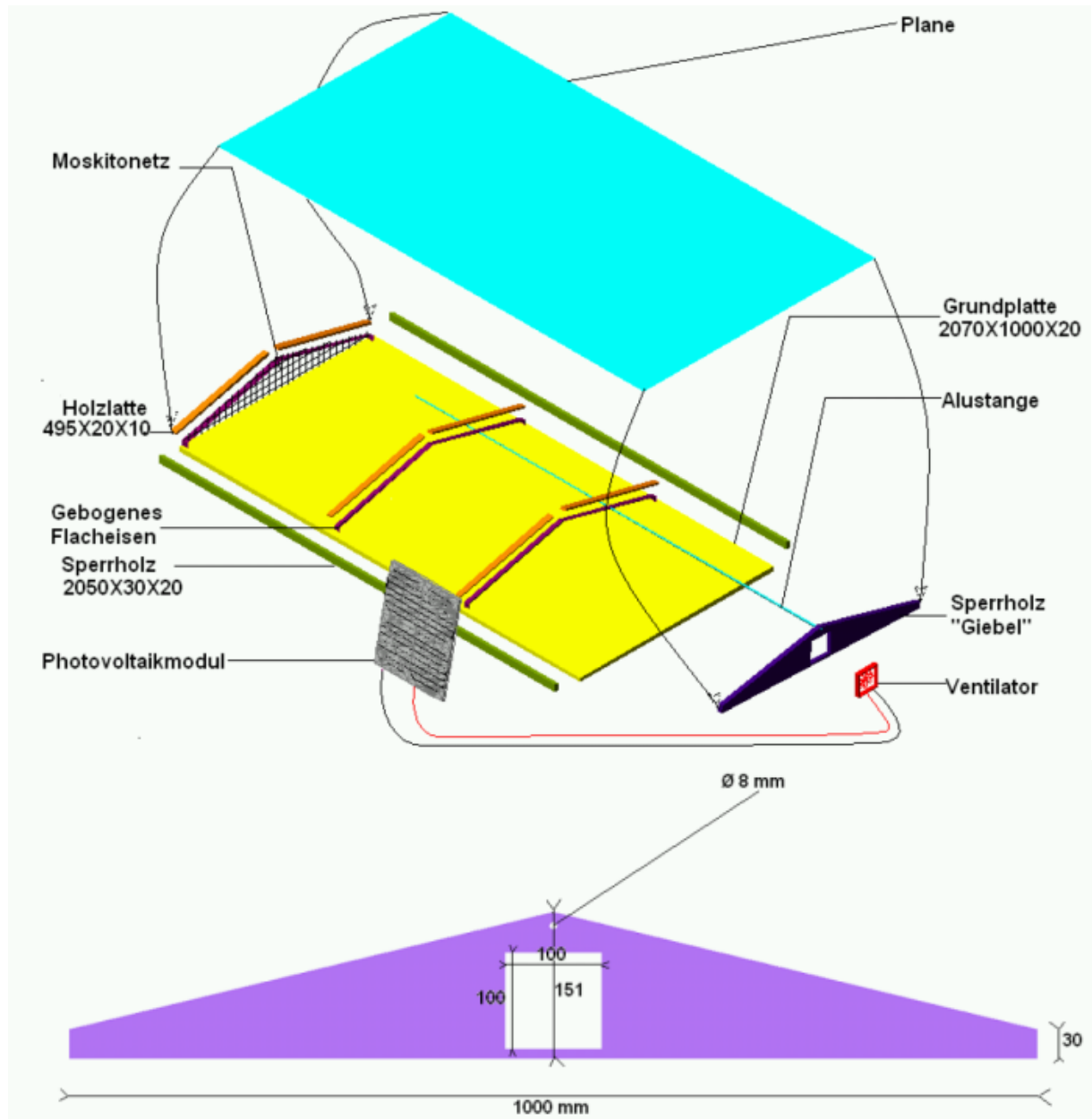

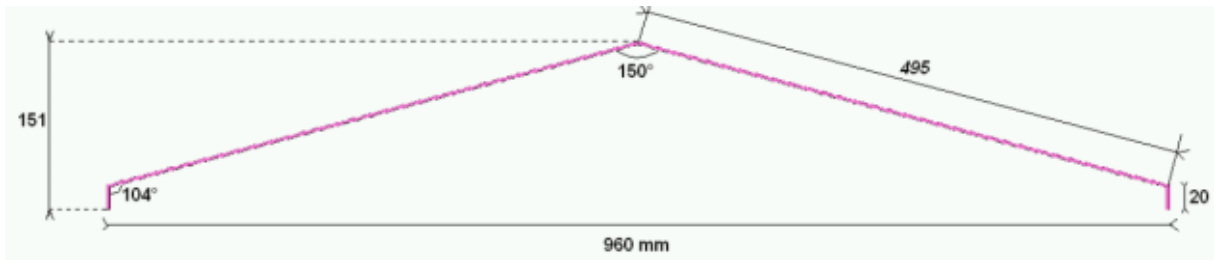

Metall Holder for the Plastic: with wood on-Top: The metal for to carry the Plastic should be covered with wood, because otherwise it would be too hot!



Complete Type 1



The air-Flow



It is great fun to prepare together the dryer.

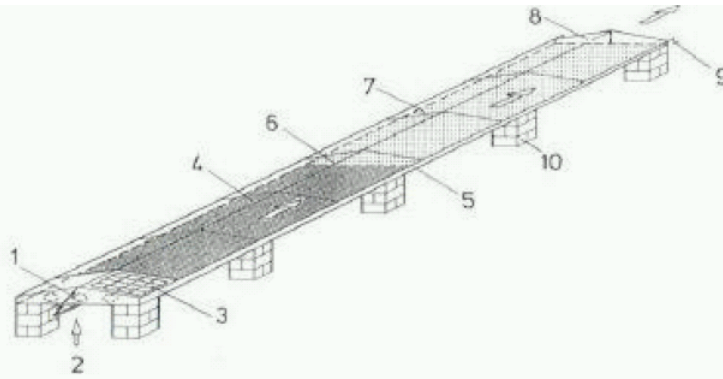

Figure 3. Solar tunnel dryer: 1.Fan, 2. Inlet air, 3.solar cell module, 4. Solar collector, 5. Metal frame, 6. Outlet of the collector, 7. Drying tunnel, 8. Outlet of drying, 9. Rolling bar, 10. Concrete block substructure

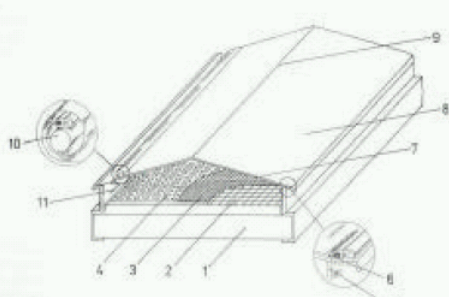

Figure 4. Drying tunnel: 1.Back insulator, 2. Wire mesh, 3. Plastic net, 4. Product to be dried, 5. Metal frame, 6. Fastening plastic profile, 7. Metal strip, 8. Air bubble plastic sheet, 9. String for supporting sheet, 10. Metal tube for rolling the sheet, 11. Rolling bar

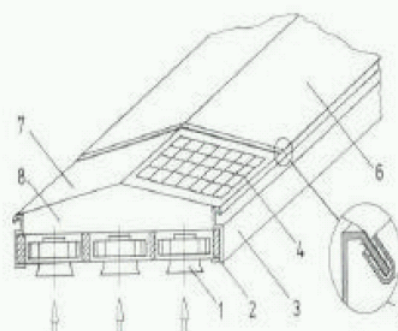

Figure 5. Solar collector: 1. Fan, 2. Back insulator, 3. Metal frame, 4. Solar cell module, 5. Reinforced plastic clamp, 6. Transparent plastic sheet, 7-8. Metal sheet

Big Size Tunnel Dryer, same design as the small one

See extra file „Summary of the book "Drying food for Profit" for more Info

Features in short

- ✓ Professional drying technology
- ✓ Operation in arid and humid regions
- ✓ Easy assembling and dismounting
- ✓ Reduction of drying time
- ✓ Improved product quality
- ✓ Hygienic drying conditions
- ✓ Protection from insects, climatic conditions, dirt
- ✓ Universal application also for sensitive products
- ✓ Low operation costs
- ✓ Operation without fuel consumption
- ✓ Grid-independant operation
- ✓ Self regulating airflow
- ✓ simultaneous temperature adjustment
- ✓ No continuous supervision necessary

Some marketing-arguments

- By drying, the taste of the fruits are intensified and the nutrients are contained more intensely and they taste more sweet and richer
- Dried fruit and vegetables are freely from preservatives.
- Dried food has a very good nutritive quality (vitamins etc)
- Dried foods are tasty, nutritious, the nutritional value and flavor of food is only minimally affected by drying
- Dried foods are high in fiber and carbohydrates and low in fat, making them healthy food choices
- Vitamin A is retained during drying
- Storage space is minimal, easy-to-store
- Dried food generates a much better benefit on the market than the unprocessed fruit.
- Transportation costs are reduced; dried Products weigh only about 1/6 of the fresh food product
- Longer storage of dried products outside the fridge!
- Children like dried food because of the sweetness.
- For diabetics dried fruit prepared without adding sugar is a healthy choice instead of desserts.
- Dried fruit can be used in stews, soups and casseroles or enjoyed as snacks. It can also be added to cereals for breakfast or used in making ice cream and baked products

Getting started

It will take some time to open the market. My experience is that there is a lot of patience necessary at the beginning, but when it runs it runs.

May be it helps to let the people try the product to convince them. And to be sensible for the feedback. Also needs time to verify which product runs best.

May be it is good to start with small quantities. Dryer also works with small quantities.

Anyway what I see in Germany, banana, pineapple, apple, mango is selling well. But good locking of the product is also important. And a nice packing, may be with a funny print. And you can proudly write on it: without any preservatives. 100 % natural!

Anyway in the beginning I think it is good not to fully depend of the income of the dryer.

Working together with other people, my be a cooperative makes you stronger.

There are different Options using this dryer:

- For family use (for the Children in the school, better than any snack. It is healthy and they like it, because there is good sugar in the dried fruits).
- For drying and marketing special products (need some sensibility what product people like).
- Offering a drying-service (people bring the product, you do processing it and they get the dried product).
- For renting to others, that they can dry by themselves and do all the work.
- Using it as a kind of glasshouse with soil, to cultivate something when there is nothing to dry. Due to the plastic, no moisture gets lost. Put plastic on the ground first.

I see so many products being dried, for example peanuts, spices, chili,;

If you are successful may be you can try to help others doing the same.

There are Micro-credits available for to start from

www.oikocredit.org or www.oikocredit.org/site/en/

www.grameen-info.org

www.banmujer.gob.ve

<http://www.cgap.org/portal/site/cgap/>

and many others.

If the quality is fine and you can deliver constant big amounts, you can try to enter the European market for example contact first this transfair-organizations (they have much better conditions):

www.gepa3.de

www.transfair.org

www.eine-welt-mvg.de

Navigate the Internet to share experience with the dryer.

Links and Resources:

Construction and Use of a Simple Solar Drier to Preserve

<http://www.hedon.info/goto.php/view/418/forum.htm>

Construction of the Tunnel Dryer:

www.efn.org/%7Eitech/Solar%20tunnel%20dryer/Solar%20tunnel%20food%20dryer%203_2008.pdf

Another example in (German language):

www.solare-bruecke.org/Bauanleitungen/Tunneltrockner_dt.pdf

This document and more:

http://www.alternative-technologie.de/Solarer_Trockner/solarer_trockner.html

<http://www.solarfood.org/>

Back-up for Solar Driers with hygroscopic Calcium Chloride

http://www.solarfood.org/solarfood2009/3_Full_papers/Technologies/53_Scheffler.pdf

<http://www.solarfood.org/projects/84-solar-food-phase-ii-afghanistan>

http://wiki.zirz.net/Mini_Tunneltrockner

http://wiki.zirz.net/Solarer_Tunneltrockner

Elnatan, a good example!

a non-profit company in Claitzdorp at the southern Cape of South Africa, turn different fruits into delicious fruit bars. Pleasant weather allows year round use of the large tunnel dryer.

The project has provided seven people with permanent employment and six with seasonal work. Ground fruit is dried and then cut into bars, some of them covered with chocolate or yoghurt, and packaged. Fruit juice is dried to a concentrate. The products are sold to hotels and in the factory's own shop.

very good documentation about Elnatan, a non-profit company in South Africa

http://www.solarfood.org/solarfood2009/3_Full_papers/SolarFood/10_Triebe.pdf

Contact

Stefan Schraner

Alternative Technologie

Frau-Holle-Weg 28

97084 Würzburg

Telefon: +49 (0)931 72353

Mobil: +49 (0)152 54690448

Email: StefanSchraner@yahoo.de

Internet: www.alternative-technologie.de